

Counterbalanced walkie stacker

Powerful 3-phase AC drive motor for maximum performance

Electric steering

Mast tilt



## EJG 212–216

### Electric Counterbalanced Walkie Stacker (2,600–3,500 lbs.)

The EJG 212-216 series of counterbalanced walkie stackers is used for loading and unloading cantilever-type storage racking or can be used where support arm walkie stackers cannot operate. With an overall width of 35.4 inches and a high degree of maneuverability, it can also be operated easily in confined warehouse areas. In addition, the EJG 212 offers a very short front dimension.

The EJG is designed to be used for ease of loading and unloading materials, along with handling:

- Special load sizes.
- Sideways lifting of pallets.
- Minimizing rack collision.

As a universal truck, the EJG offers a number of advantages:

- Gentle depositing of the load on the floor or in the racking with proportional hydraulics.
- Minimum noise during lifting.
- Electric tiller provides greatly reduced steering force for fatigue-free steering.
- Extremely sturdy frame and load section.
- High ground clearance and large load wheels for comfortable travel on uneven surfaces.

The EJG battery compartment accepts a 24-volt industrial battery. Battery compartments for lateral battery exchange are available for multi-shift operations (optional).

**JUNGHEINRICH®**

# EJG 212 / 214 / 216

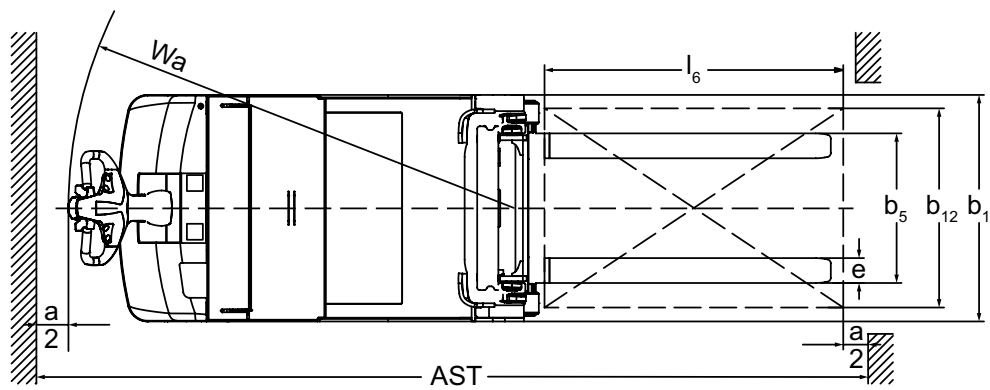
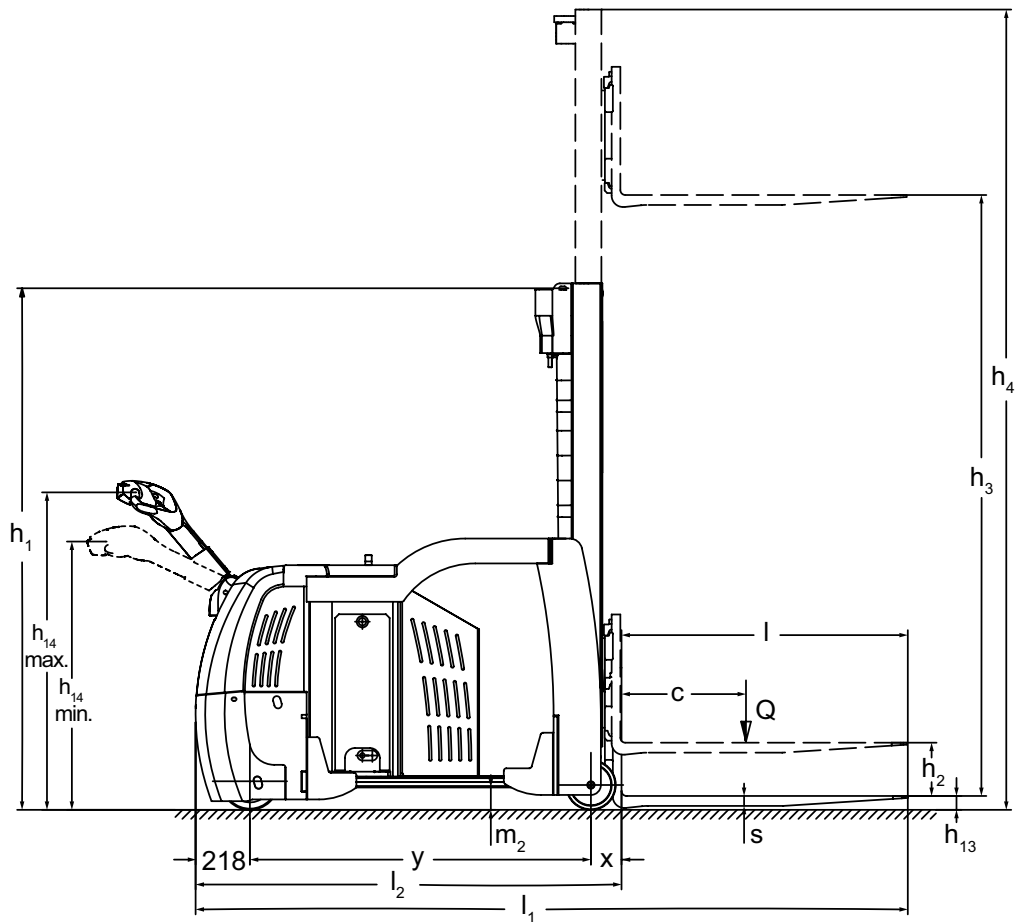

# Technical Data

as of: 11/2018

Characteristics	1.1	Manufacturer				Jungheinrich®		Jungheinrich®		Jungheinrich®		
	1.2	Model				<b>EJG 212</b>		<b>EJG 214</b>		<b>EJG 216</b>		
	1.3	Drive				electric		electric		electric		
	1.4	Type				counterbalanced walkie stacker		counterbalanced walkie stacker		counterbalanced walkie stacker		
	1.5	Load capacity / rated load	Q	lbs	kg	2,646	1,200	3,086	1,400	3,527	1,600	
	1.6	Load center distance	c	in	mm	19.7	500	19.7	500	19.7	500	
	1.9	Wheelbase	y	in	mm	44.5	1,130	49.2	1,250	53.9	1,370	
Weights	2.1	Service weight without battery			lbs	kg	4,341	1,969	4,363	1,979	4,385	1,989
	2.2	Axle loading – loaded, front / rear <sup>1)</sup>			lbs	kg	1,510 / 6,151	685 / 2,790	1,510 / 6,614	685 / 3,000	1,510 / 7,077	685 / 3,210
	2.3	Axle loading – unloaded, front / rear <sup>1)</sup>			lbs	kg	2,954 / 2,061	1,340 / 935	3,031 / 2,006	1,375 / 910	3,109 / 1,951	1,410 / 885
Wheels, Chassis	3.1	Tires				Vulkollan®		Vulkollan®		Vulkollan®		
	3.2	Tire size, front				mm		230 x 100		230 x 100		
	3.3	Tire size, rear				mm		200 x 100		200 x 100		
	3.5	Wheels – number, front / rear (x=driven)						1 / 2		1 / 2		
Dimensions	4.2	Lowered height (OAL) <sup>2)</sup>	h <sub>1</sub>	in	mm	85.2	2,165	85.2	2,165	85.2	2,165	
	4.3	Fork free lift height (FFH) <sup>2)</sup>	h <sub>2</sub>	in	mm	3.9	100	3.9	100	3.9	100	
	4.4	Maximum fork height (MFH) <sup>2)</sup>	h <sub>3</sub>	in	mm	114.2	2,900	114.2	2,900	110.2	2,800	
	4.5	Extended mast height (OAE) <sup>2) 3)</sup>	h <sub>4</sub>	in	mm	145.1	3,685	145.1	3,685	141.1	3,585	
	4.9	Handle height in drive position, minimum / maximum	h <sub>14</sub>	in	mm	42.5 / 50.6	1,080 / 1,285	42.5 / 50.6	1,080 / 1,285	42.5 / 50.6	1,080 / 1,285	
	4.15	Height, lowered	h <sub>13</sub>	in	mm	2.0	50	2.0	50	2.0	50	
	4.19	Overall length	l <sub>1</sub>	in	mm	103.5	2,630	108.3	2,750	113.0	2,870	
	4.20	Length to fork face, headlength	l <sub>2</sub>	in	mm	58.3	1,480	63.0	1,600	67.7	1,720	
	4.21	Overall width	b <sub>1</sub>	in	mm	35.4	900	35.4	900	35.4	900	
	4.22	Fork dimensions, thickness / width	s/e	in	mm	1.6 / 3.1	40 / 80	1.6 / 3.1	40 / 80	1.6 / 3.1	40 / 80	
	4.23	Fork carriage ISO 2328, class/type A/B	b <sub>2</sub>	in	mm	2B		2B		2B		
	4.24	Fork carriage width	b <sub>3</sub>	in	mm	26.8	680	26.8	680	26.8	680	
	4.25	Width across forks	b <sub>5</sub>	in	mm	22.8	580	22.8	580	22.8	580	
	4.32	Ground clearance, center of wheelbase	m <sub>2</sub>	in	mm	3.5	90	3.5	90	3.5	90	
	4.32.1	Ground clearance, load wheelbase	m <sub>2</sub>	in	mm	2.4	60	2.4	60	2.4	60	
4.32.2	Ground clearance, drive unit wheelbase	m <sub>2</sub>	in	mm	1.4	35	1.4	35	1.4	35		
4.34	Aisle width for pallets 800 x 1200 lengthways	Ast	in	mm	122.4	3,110	127.2	3,230	131.9	3,350		
4.35	Turning radius	Wa	in	mm	64.2	1,630	68.9	1,750	73.6	1,870		
Performance	5.1	Travel speed, loaded / unloaded			mph	km/h	3.6 / 3.6	5.8 / 5.8	3.6 / 3.6	5.8 / 5.8	3.6 / 3.6	5.8 / 5.8
	5.2	Lift speed, loaded / unloaded			ft / min	km/h	29.5 / 49.2	0.15 / 0.25	29.5 / 49.2	0.15 / 0.25	29.5 / 49.2	0.15 / 0.25
	5.3	Lowering speed, loaded / unloaded			ft / min	m / s	72.8 / 67	0.37 / 0.34	72.8 / 67	0.37 / 0.34	72.8 / 67	0.37 / 0.34
	5.10	Service brake						electric		electric		electric
Motors	6.1	Drive motor (output S <sub>2</sub> 60 min.)			hp / kW		3.8 / 2.8		3.8 / 2.8		3.8 / 2.8	
	6.2	Lift motor (output at S <sub>3</sub> 15%)			hp / kW		4.0 / 3.0		4.0 / 3.0		4.0 / 3.0	
	6.4	Battery voltage, nominal capacity K5			V / Ah		24 / 375		24 / 375		24 / 375	
	6.5	Battery weight, minimum / maximum			lbs	kg	624 / 690	283 / 313	624 / 690	283 / 313	624 / 690	283 / 313
	Misc.	8.1	Type of drive control				AC speedCONTROL		AC speedCONTROL		AC speedCONTROL	

1) includes battery weight (see section 6.5)

2) mast example (Two Stage Simplex). Taller and shorter masts are available. Duplex and triplex masts available.

3) excludes load backrest

This specification sheet only provides technical values for the standard truck. Non-standard tires, different masts, additional equipment, etc., could produce other values. Rights reserved for technical changes and improvements.

# The Jungheinrich Advantage



Ergonomic operating handle



Increase in ground clearance with large load wheels



Excellent view of the load for precise positioning



Lateral battery exchange (optional)

## Cantilever stacking

- The cantilever design without interference from support arms allows the transport of sideways pallets or special load carriers
- The generous ground clearance with 7.5-inch load wheels allows the truck to travel over uneven surfaces and low thresholds
- The short overall length makes maneuverability easier in confined areas

## Accurate and comfortable stacking and retrieval

- All lifting and lowering functions are intuitively controlled with the multi-functional tiller arm. This allows the operator to concentrate fully on stacking and retrieving:
- Precise load lifting by speed-controlled and noise-reduced hydraulic motor
  - Gentle depositing of loads using proportional hydraulics
  - Automatic reduction in speed with raised load

## Robust design

The EJK is designed for high-throughput operation:

- 8 mm steel frame
- Closed frame

## Intelligent control and drive technology

Jungheinrich 3-phase AC motors with electronic control are tuned perfectly to the application, offering higher performance and low running costs. Make the most of these advantages:

- High level of efficiency with excellent energy management
- Powerful acceleration
- Rapid direction change

## Batteries

- Battery compartment accepts a 24-volt industrial battery
- Lateral battery rollers for side extraction opening (optional)

## Additional equipment

- CanDis control instrument
- CanCode access control
- Cold store version
- Load guard

## Parts when you need them

Jungheinrich's Parts Fast or Parts Free Guarantee ensures next-business-day delivery by 5:00 p.m. of all Jungheinrich parts in the United States, or they're free, including freight. For customers in Canada and Mexico, the guarantee ensures shipping of parts within 24 hours from the time the order was placed by the dealer. See your local Jungheinrich dealer for program details.

- \* Programs may be subject to change without notice and may vary by region. Please ask your local Jungheinrich dealer for complete terms and conditions.